

Reduction of Energetic Proton Lifetime in the Inner Radiation Belt by Artificial Means

**Dennis Papadopoulos and
X. Shao
University of Maryland**

**Acknowledge: Tom Wallace
and C.L. Chang
BAE Systems-AT**

**Invited Paper
Session:15-3
43th Annual
GOMACTech
Conference
Orlando, FL
March 16-19,
2009**

Electron Radiation Belt Remediation (RBR)

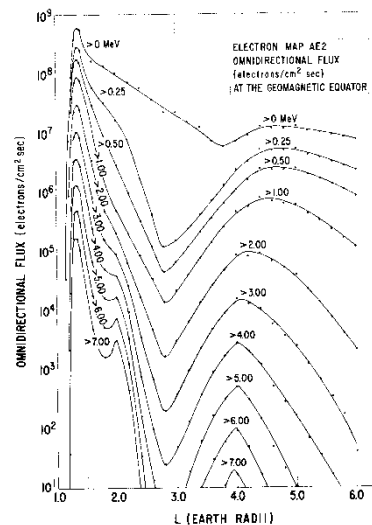
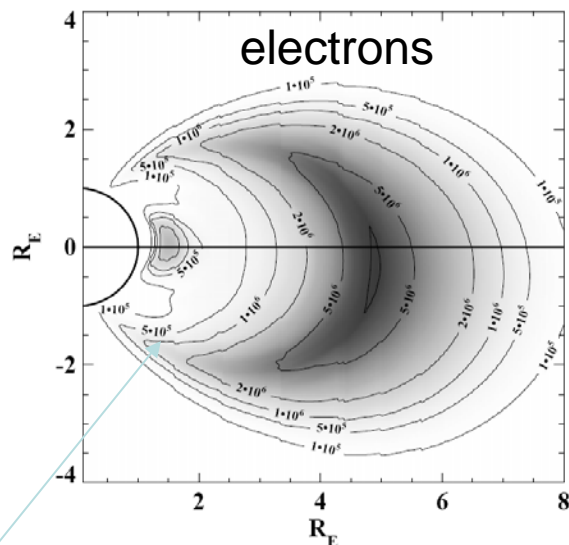
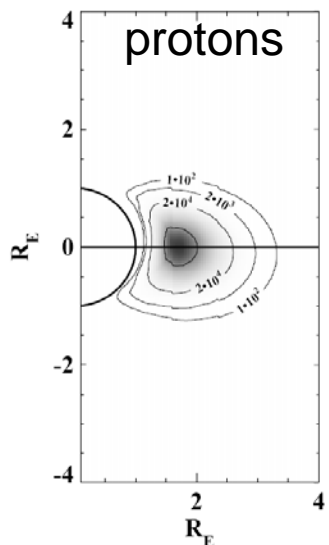

RBR how ?

Why slot ? Presence of whistler waves due to extraneous sources – VLF stations + Lightning

Inject ELF/VLF waves artificially in the shells affected by HAND to enhance precipitation rate. Lifetime of weeks or less.. Inan – Ginet – Ganguli – Papadopoulos - Tether report]

DSX - SPIDER

- Two electron belts with a slot region in between. Good location for low shielded satellites.
- A HAND injects large flux of MeV electrons. Shortens useful lifetime to days or weeks.
- RBR seeks to reduce flux in timescales of days or weeks

Physics of RBR Induced Precipitation

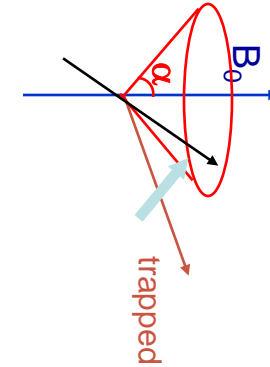
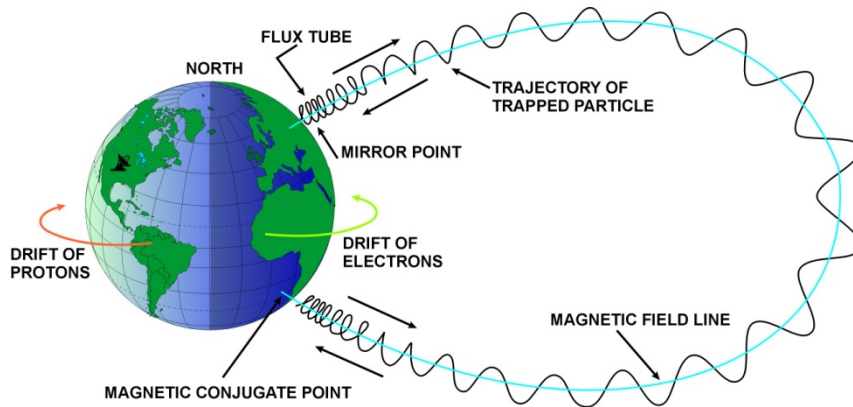

Resonant interaction of whistler waves with relativistic electrons leading to pitch angle scattering – Need km wavelengths -> kHz frequency

$$\omega - k_z v_z = \mp n |\Omega_e| / \gamma$$

$$k_z v_z \approx \mp |\Omega_e| / \gamma$$

- Inject waves using a fleet of space -based VLF transmitters (DSX)
- Inject waves by low ionization potential neutral gas releases (SPIDER)
- Ground base option ?

$$T \propto (1/|\Omega_e|)(B_o / B_w)^2$$

Proton RBR – The Inner Belt Protons

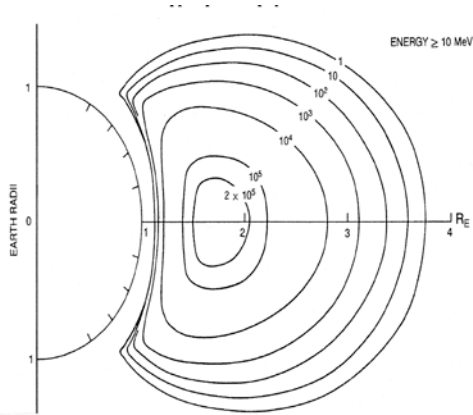

Omnidirectional, integral proton flux with energy greater than 10 MeV. Based on data supplied by the National Space Science Data Center.

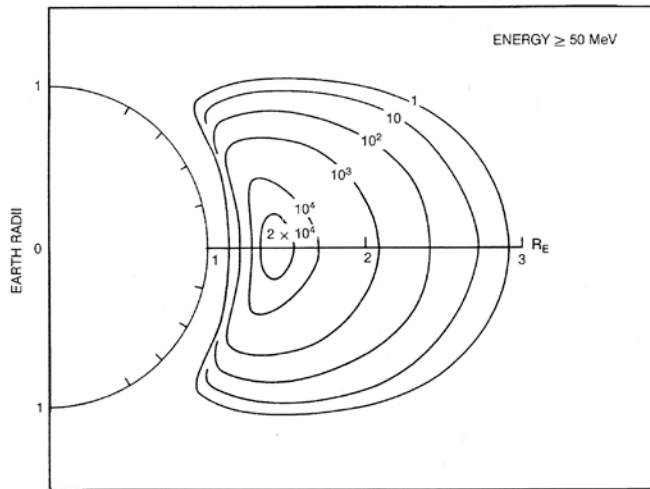

Omnidirectional, integral proton flux with energy greater than 50 MeV. Based on data supplied by the National Space Science Data Center.

L = 1.5-1.8

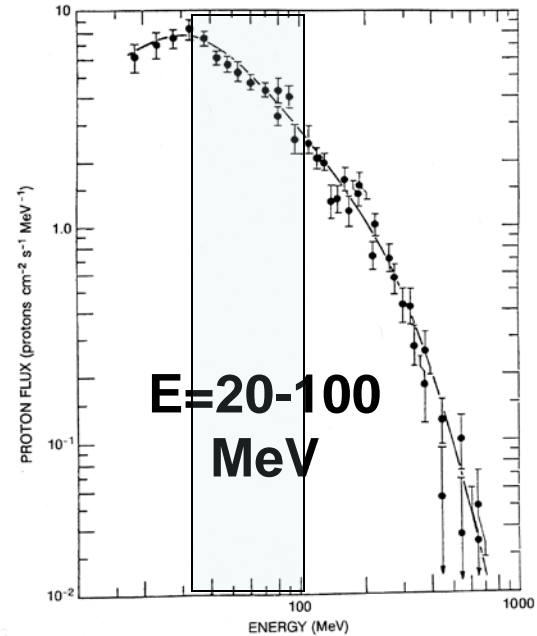

Differential energy spectrum of protons in the inner radiation zone.

Bermuda Triangle of Satellites

SAA

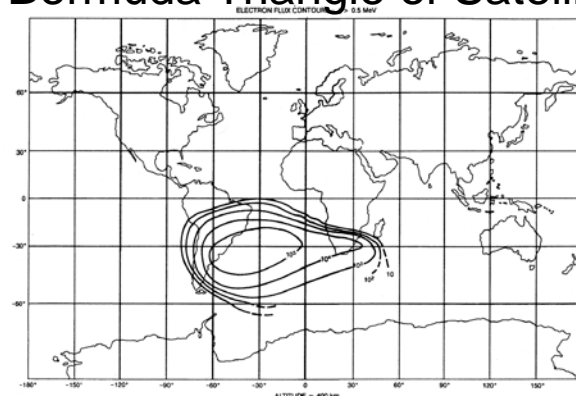

Radiation concentration at the South Atlantic anomaly. Isointensity contours of electrons above 0.5 MeV at an altitude of 400 km.

Proton Effects on Commercial-Off-The-Shelf (COTS) Electronics

- **Higher LEO Orbits: commercial electronics are regularly affected by proton upsets**
- **Lower LEO Orbits: affected during SAA transits and at high latitudes**
- **Example: IBM PowerPC 603 in Iridium (0.5 micron CMOS) – cache had to be disabled because of upsets caused by SAA**

Issues with using COTS in LEO Orbiting Platforms

- **COTS feature decrease increases rate of proton induced upsets (Gallaway)**
- **Critical charge for upset scales as (feature size)²**
 - For large feature sizes, protons induce charge by releasing secondaries that deposit charge
 - At 65 nm and smaller, a proton deposits enough charge in silicon to cause an upset directly
- **This can increase the proton SEU cross section by 2-3 orders of magnitude for deep submicron devices**
- **Major issue for micro-satellites**

**IS PRBR A SOLUTION AND
WHAT DOES IT TAKE**

PRBR by Injection of Shear Alfvén Waves (SAW) from Ground Transmitters

- **Removal same way as HANE RBR. Increase proton precipitation rate by enhancing proton pitch angle scattering into the loss cone.**
- **Enhanced pitch angle scattering requires interaction with resonant waves – SAW with frequency in the 1 – 15 Hz band.**
- **Unlike HANE electrons, inner belt protons are injected slowly (>30 years) (CRAND). PRBR can be done periodically (e.g. for 1-2 years every 10 years) as well as monitored**
- **PRBR would have an immediate operational impact, as well as alleviate current problems**

Proton Lifetime in the Inner Radiation Belt

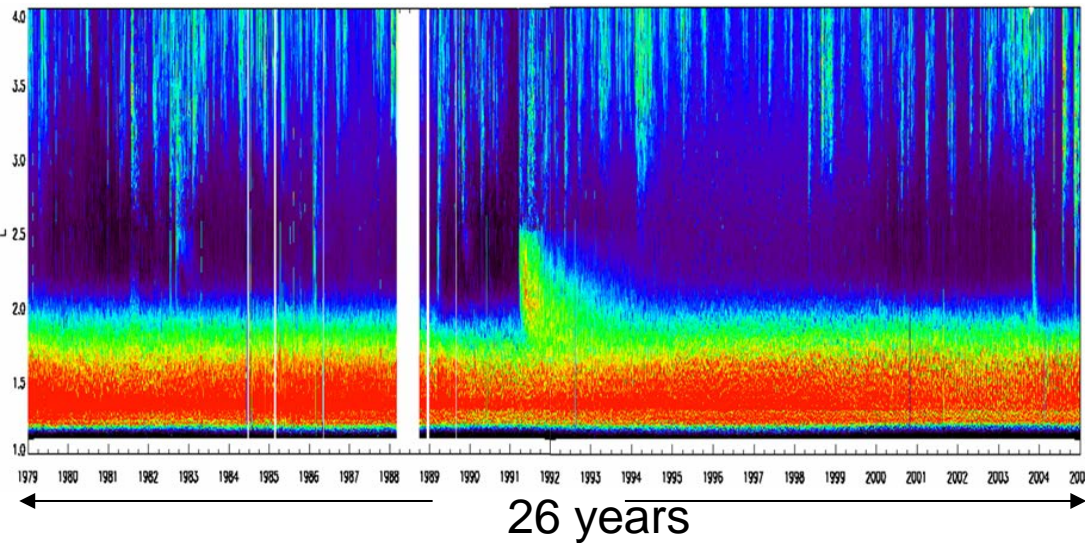

Steady State → Source = Loss

Loss → Slowing down by exciting and ionizing electrons in the thermosphere

$$T \approx 2 \times 10^4 (E / \text{MeV})^{1.3} (\# \text{cm}^3 / \langle \rho \rangle) \text{ years}$$

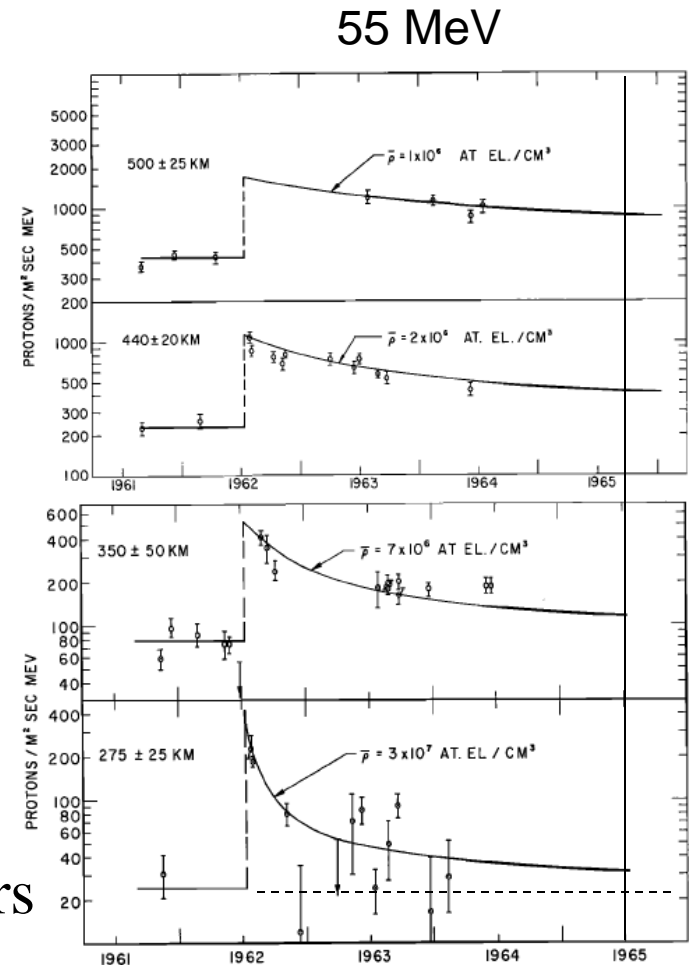

Fig. 10. Time variation of the 55-MeV proton flux for altitudes of $H_o = 275, 350, 440,$ and 500 km from August 1961 to July 1964. The solid curves drawn for the period after July 1962 are the theoretical decay curves based on the first data point following July 1962.

INNER RB PROTON SOURCE AND LOSS

$$\frac{dN(E)}{dt} = S(E) + \frac{d}{dE} \left(N(E) \frac{dE}{dt} \right)$$

$$\frac{dE}{dt} = v \frac{dE}{dx} \sim \langle \rho \rangle$$

Slowing down by exciting and ionizing electrons of Oxygen atoms in the thermosphere

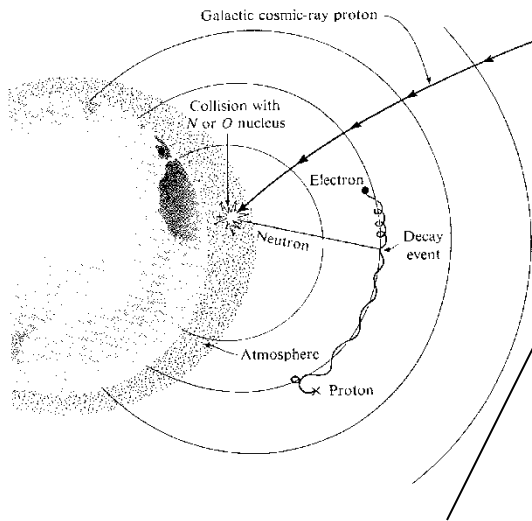

$$S(E) = - \frac{d}{dE} \left(N(E) \frac{dE}{dt} \right)$$

**Cosmic Ray Albedo
Neutron Decay
(CRAND)**

No natural or other ULF wave activity in inner RB

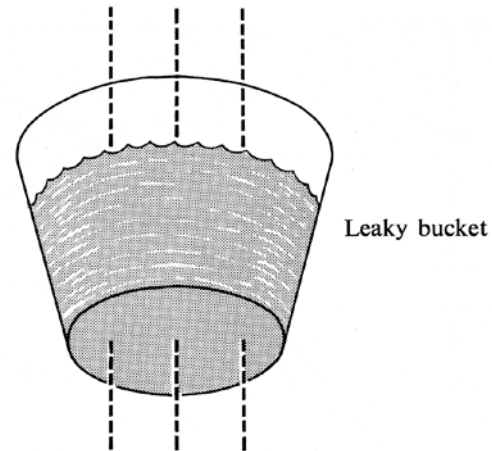

**INJECT ULF WAVES TO INDUCE A
FASTER LOSS RATE**

Schematic of PRBR Concept

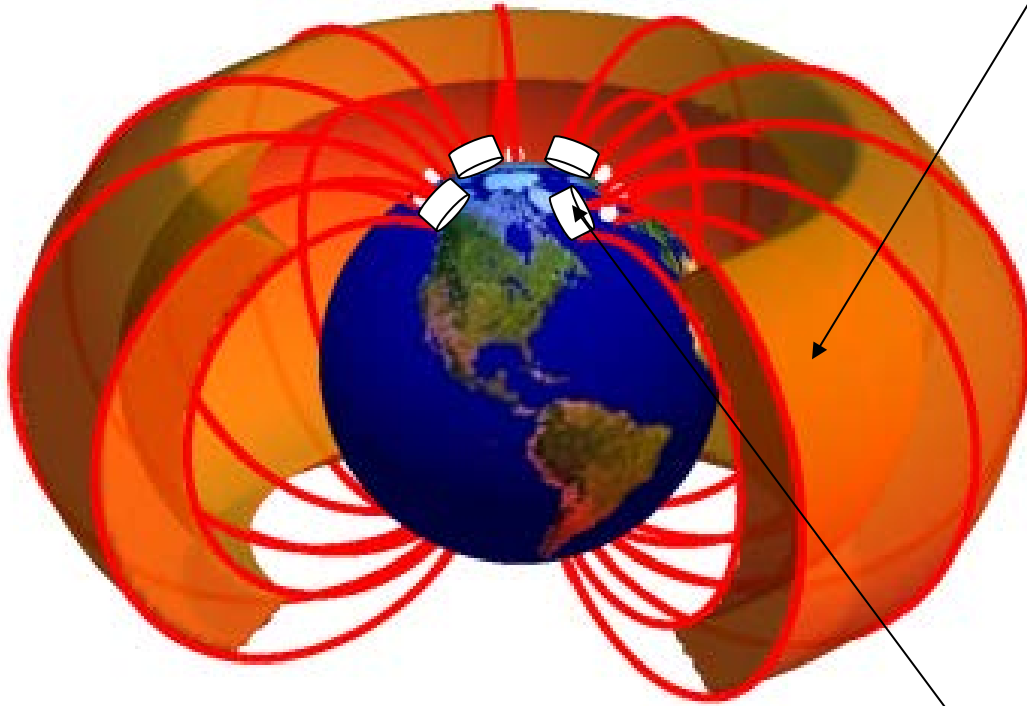

Maintain an average amplitude of approximately 25 pT of Shear Alfvén Waves (SAW) with 5-15 Hz frequency in the L=1.5-1.8 shells of the inner belt. These waves induce Pitch Angle Diffusion (PAD) on 30-100 MeV protons, by satisfying the resonance condition

$$\omega - k_z v_z = \pm \Omega$$

$$k_z v_z \approx \Omega$$

SAW injected using ground based transmitters

- Energy stored in volume for $\Delta L = .1$ is 75 kJ
- Loss time for 30-100 MeV protons < 3 years
- Injection power required to maintain it depends on SAW confinement time ~ 3-7 KW

Proton-SAW Gyro-Resonant Condition

Gyro-Resonant Condition:

$$\omega - k_z v_z = \pm \Omega / \gamma$$

$$\Omega \approx k_z v_z \quad (\text{non-relativistic proton, } \omega \ll \Omega)$$

SAW Dispersion Relation:

$$\omega = k_z V_A$$

Gyro-Resonant Condition for proton (v, α) with SAW:

$$\omega(v, \alpha) = \frac{\Omega}{\cos \alpha} \frac{V_A}{v}$$

Frequency Selection for Proton-SAW Resonance

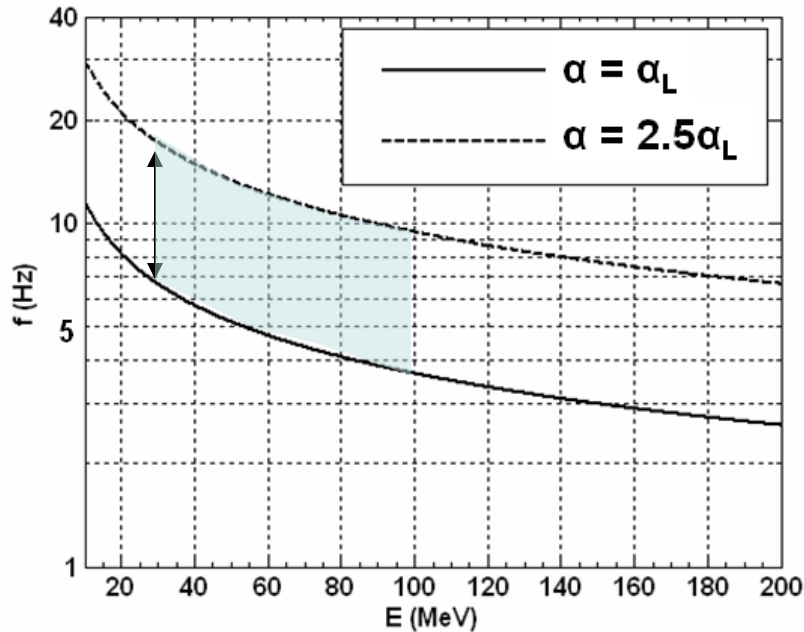

$$\omega(E, \alpha) = \frac{\Omega}{\cos \alpha} \sqrt{\frac{MV_A^2}{2E}}$$

Proton Energy	Frequency Range
30 MeV	6-16 Hz
50 MeV	5-15 Hz
100 MeV	3.5-9.5Hz

Frequency requirement for equatorial Proton-SAW resonance with at L=1.5

$$\alpha_L = 28 \text{ degree}$$

Frequency range ~ 5-15 Hz

Effective (averaged) PAD Estimate

Consider broadband spectrum of
SAW

$$W(\omega) \propto \exp(-(f - f_0)^2 / \delta f^2)$$

i.e., $f_0 = 10\text{Hz}$, $\delta f = f_0 / 2$

1. Local Pitch Angle Diffusion (PAD) rate

$$D_{\alpha\alpha} = \Omega \frac{\delta B(\lambda)^2}{B(\lambda)^2} \frac{\omega(v, \alpha)}{\delta \omega} \exp(-(\omega(v, \alpha) - \omega_0)^2 / \delta \omega^2)$$

2. PAD averaged over bounce time

$$\langle D_{\alpha\alpha} \rangle_B = \frac{1}{2S(\alpha_E)} \int_{\lambda_{M1}}^{\lambda_{M2}} D_{\alpha\alpha} \frac{\cos(\alpha)}{\cos^2(\alpha_E)} d\lambda \cos^7(\lambda)$$

$$\langle D_{\alpha\alpha} \rangle_B \propto \delta B^2(\lambda = 0, \varphi) / 2\mu_0$$

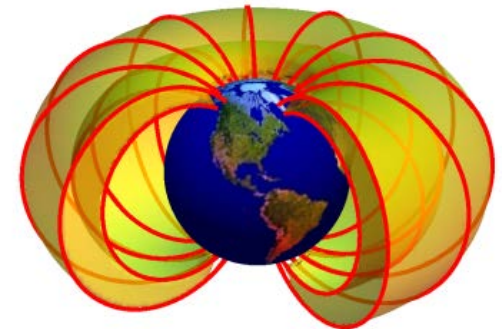

λ is the latitude and φ is the azimuthal angle

Averaged PAD Rate

3. Drift-Averaged Pitch Angle Diffusion Rate

$$\langle D_{\alpha\alpha} \rangle_D = \frac{1}{(2\pi r / V_D)} \oint \langle D_{\alpha\alpha} \rangle_B \frac{rd\varphi}{V_D} = \frac{1}{2\pi} \oint \langle D_{\alpha\alpha} \rangle_B d\varphi$$
$$\frac{\langle \delta B^2 \rangle}{2\mu_0} = \frac{\text{SAW Energy}}{\text{Volume}}$$
$$\propto \frac{1}{2\pi} F \oint \delta B(\lambda = 0, \varphi)^2 d\varphi \propto \frac{\langle \delta B^2 \rangle}{2\mu_0}$$

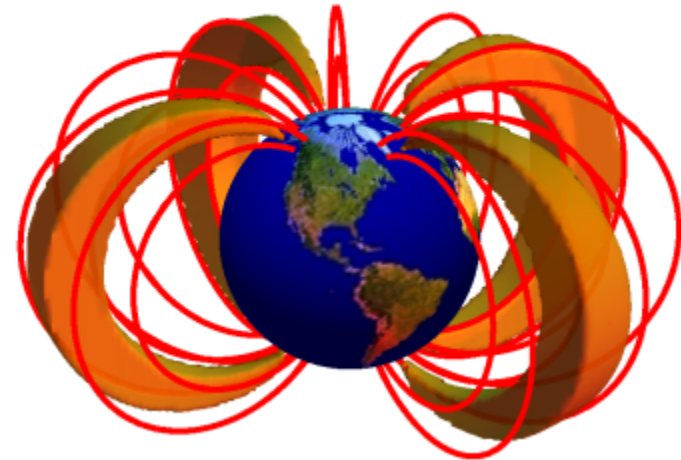
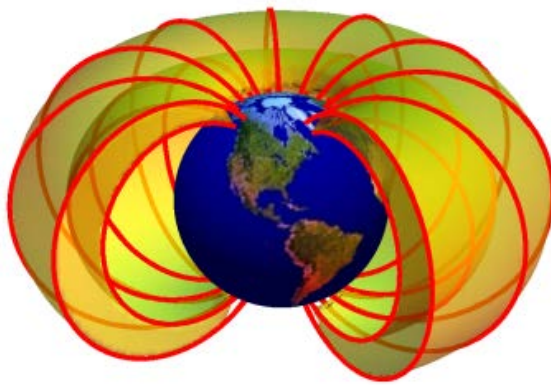

- Pitch angle scattering amount is proportional to the stored SAW energy the proton experiences during its bounce-drift orbit.

Proton Lifetime Estimates

Solve Pitch-Angle Diffusion Equation

$$\frac{\partial f_0}{\partial t} = \frac{1}{S(\alpha_0) \sin(\alpha_0) \cos(\alpha_0)} \frac{\partial}{\partial \alpha_0} \left[S(\alpha_0) \sin(\alpha_0) \cos(\alpha_0) \langle D_{\alpha\alpha} \rangle_D \frac{\partial f_0}{\partial \alpha_0} \right] - f_0 / \tau_{atm}$$

$f_0(t, \alpha_0) = F(t) g(E, L, \alpha_0)$ Split temporal and pitch angle distribution

(Life Time) $\tau_p = -\left(\frac{1}{F} \frac{\partial F}{\partial t}\right)^{-1}$

$$\left(\frac{1}{\tau_{atm}} - \frac{1}{\tau_p}\right) g(\alpha_0) S(\alpha_0) \sin(\alpha_0) \cos(\alpha_0) = \frac{\partial}{\partial \alpha_0} S(\alpha_0) \sin(\alpha_0) \cos(\alpha_0) \langle D_{\alpha\alpha} \rangle \frac{\partial g}{\partial \alpha_0}$$

- Use finite-difference to discretize $g(E, L, \alpha_{0,i})$
- Use iterative method to solve nonlinear eigen-value problem for lifetime

Proton Lifetime

	$f_1 = 6.5 \text{ Hz}$	$f_2 = 10 \text{ Hz}$	$f_3 = 13 \text{ Hz}$
E = 30 MeV	1688 days	880 days	595 days
E = 50 MeV	900 days	586 days	920 days
E = 100 MeV	580 days	1032 days	1600 days

- $\Delta f/f = 1/2$, Energy stored in SAW at $L = 1.5$ and $\Delta L = .1$ is $W = 75 \text{ kJ}$
- Life time of (30-100 MeV) protons can be reduced to 2-3 years.

INJECTION POWER REQUIREMENTS

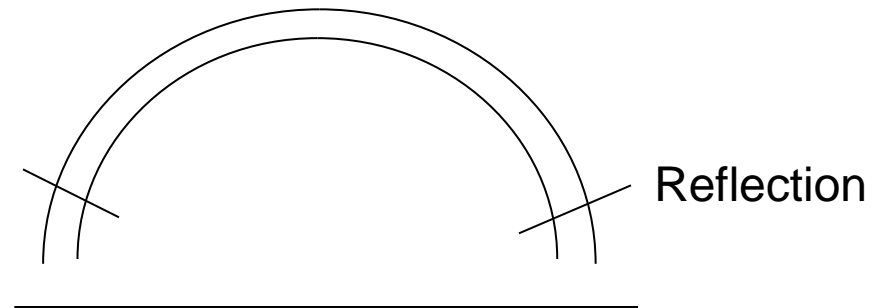
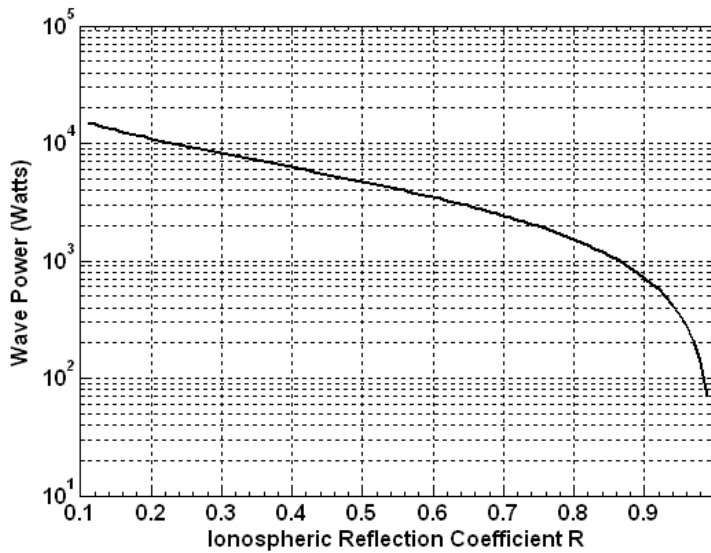

**Injection power required to maintain
75 kJ at L=1.5 per .1 L width**

Injection of SAW

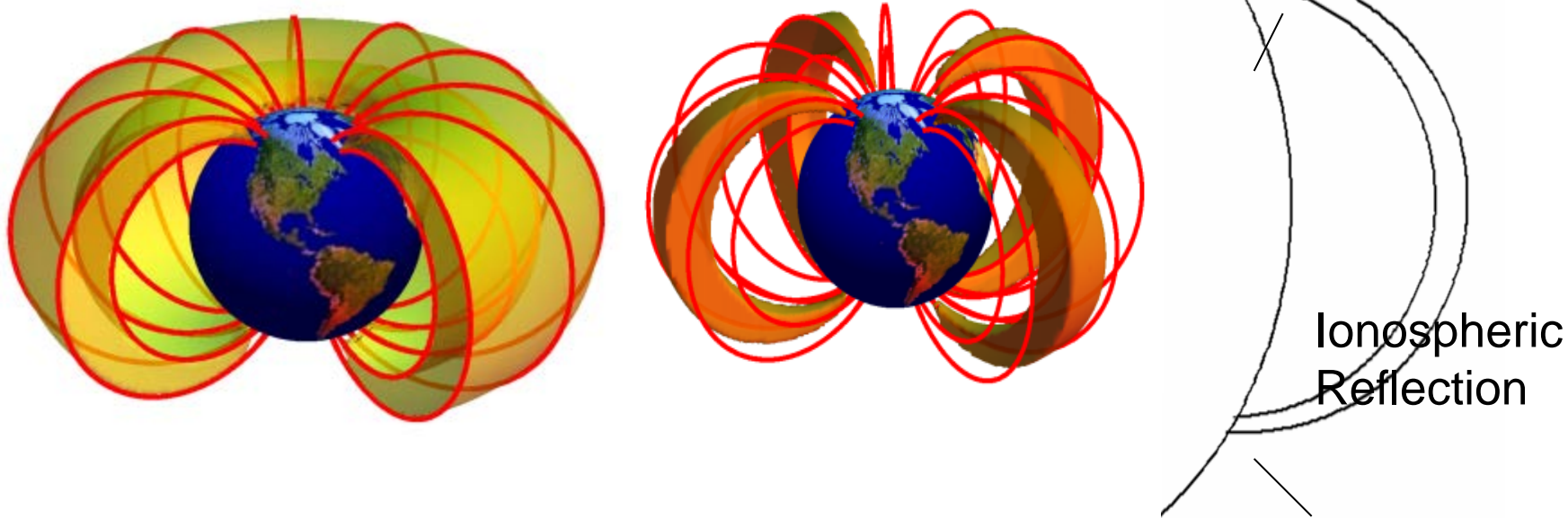

- Injection can be carried out at selected sites
- The remediation effects will be the same for global or sector injection as long as the total stored SAW resonance energy is the same.
- SAW is trapped inside the flux tube
- The loss of SAW mainly occurs at the ionospheric boundary.

Ground-based Conventional Transmitter - HED

To inject 1 kW we require $\langle b \rangle \approx 30$ pT at 75 km, the bottom of the magnetized ionosphere.

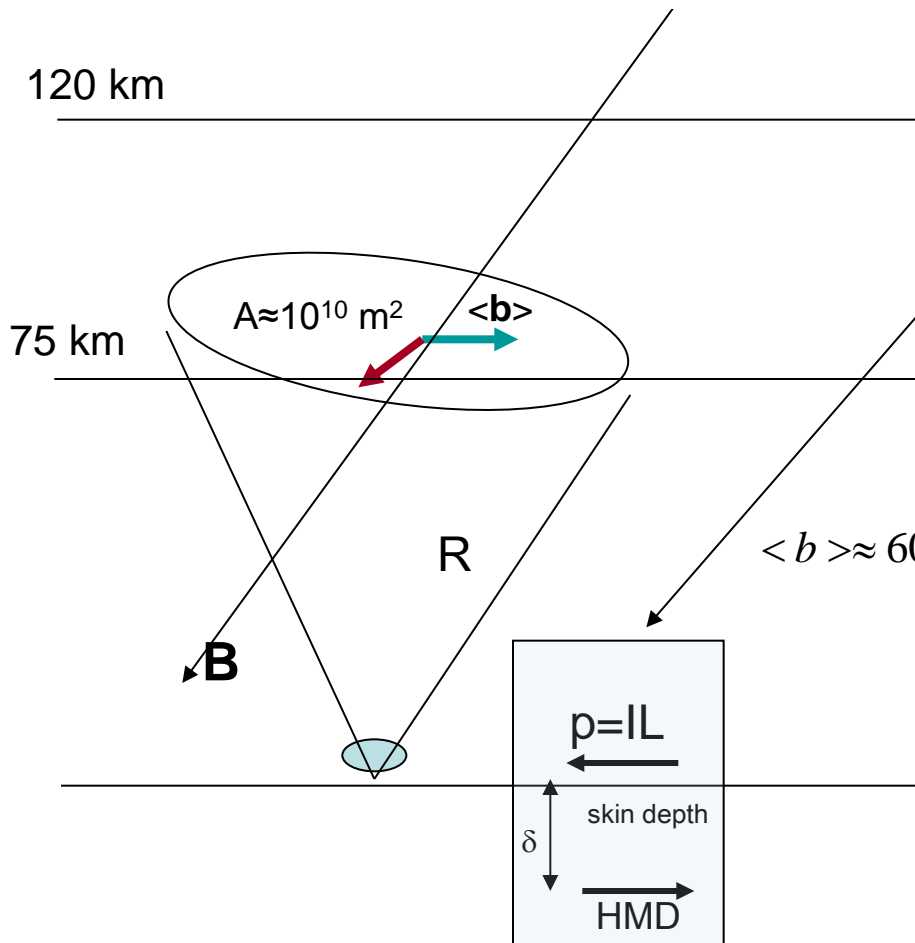

Conventional ULF/ELF sources (like Sanguine/Seafarer) are grounded wires – HED (Jason Study by Perkins et al.)

$$\langle b \rangle \approx 60(IL^2 / 2 \times 10^{10}) \left[\frac{\delta}{2(L + \delta)} \right] pT \approx 30(IL^2 / 2 \times 10^{10}) pT$$

Need $M \approx IL^2 \approx 2 \times 10^{10} \text{ A-m}^2$

Ground-based Rotating Magnet Array (RMA)

To inject 1 kW we require $\langle b \rangle \approx 30$ pT at 75 km, the bottom of the magnetized ionosphere.

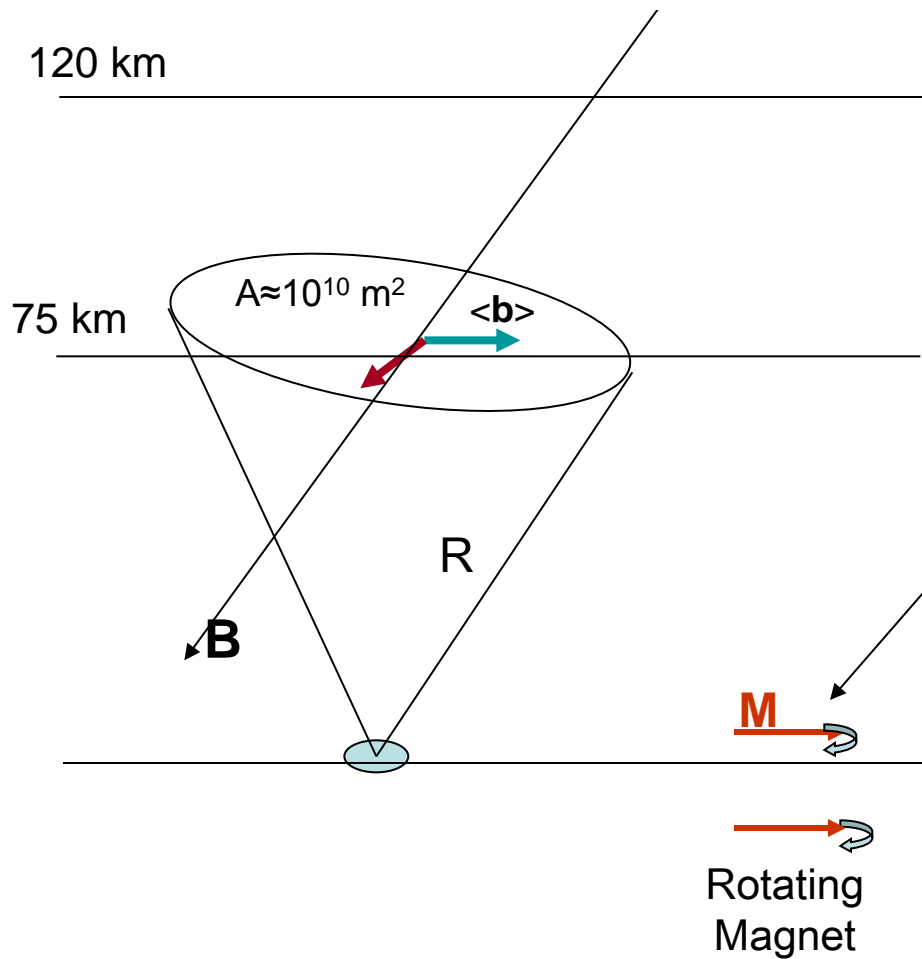

A superconducting magnet rotating at a ULF frequency has a reflected image in phase with primary

$$\langle b \rangle \approx 30(M / 5 \times 10^9) pT$$

Need RMA with $M \approx 5 \times 10^9$ A-m²

Innovative Sources: Rotating Magnets

- Rotating superconducting magnets are useful for frequencies of up to 10 Hz
- They are compact sources of large moments and can be used in arrays
- Example design:
 - Superconducting coil 5 m high x 5 m wide x 5 m long
 - 25 m² area
 - 100 Amps DC current
 - 4×10^4 turns
 - $M = 10^8$ A-m² per coil, meaning 50 coils are needed
- Cost estimate: ~\$1M/coil
 - LTS wire at \$2/kA-m: \$160k/coil
 - Dewar and refrigeration: \$500k/coil (assuming LHe large plant shared across dozens of coils)
 - Mechanical rotation: \$300k/coil (depends strongly on maximum frequency)

Sneak-through Concept

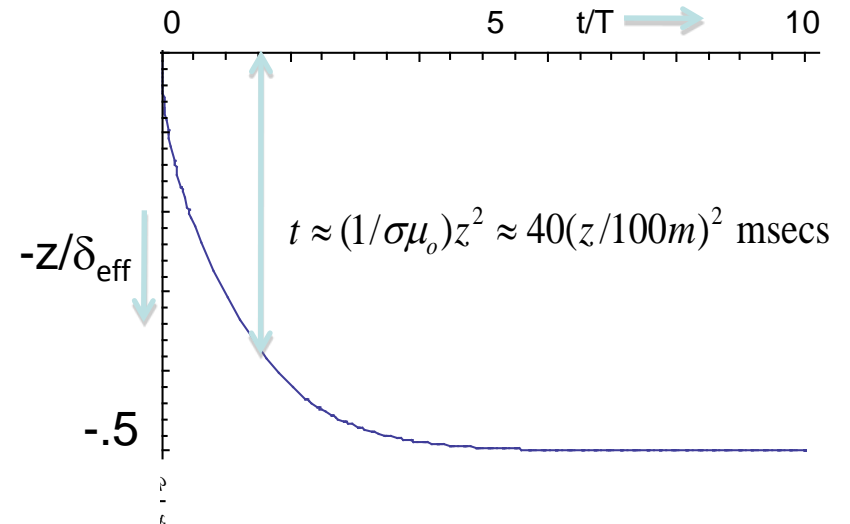
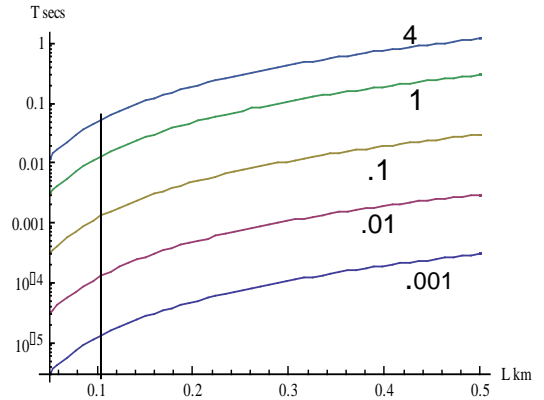
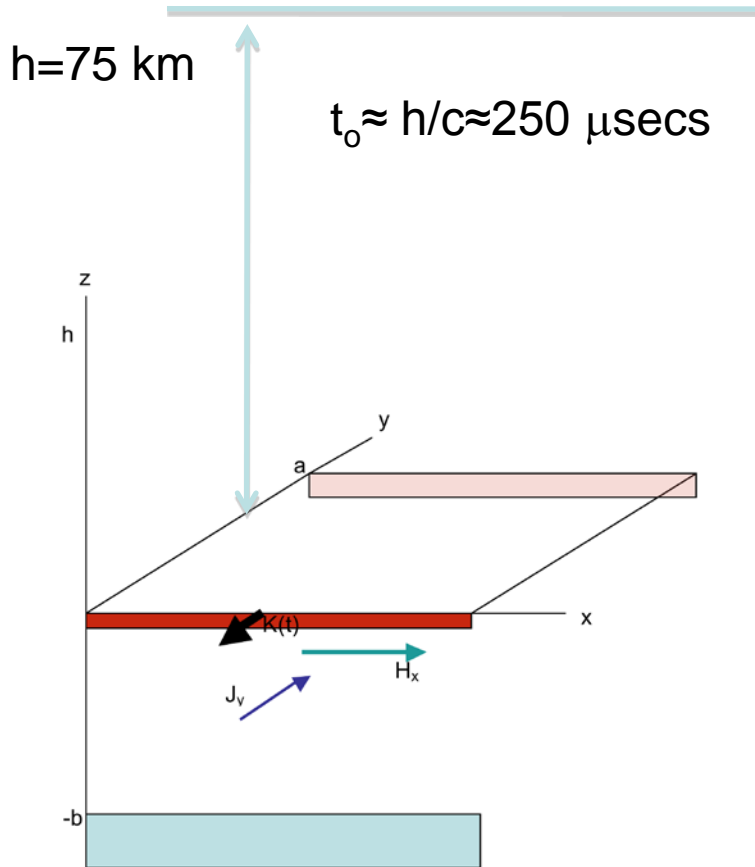

Sneak-through Concept

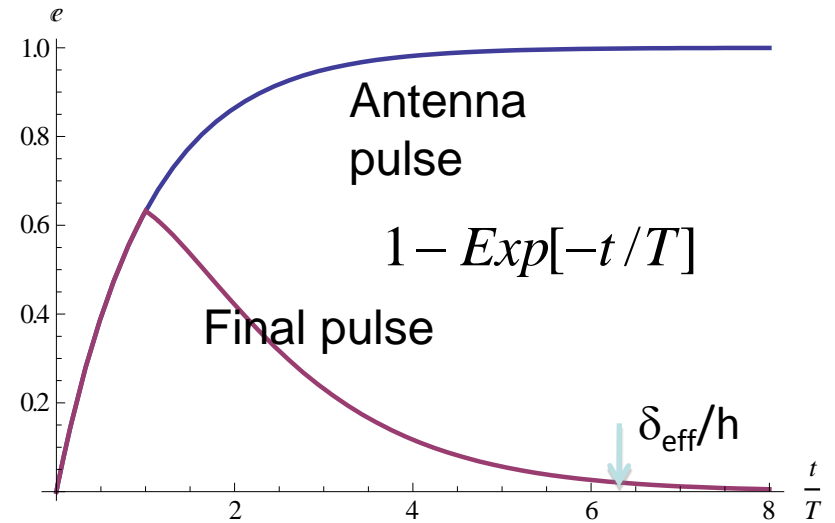
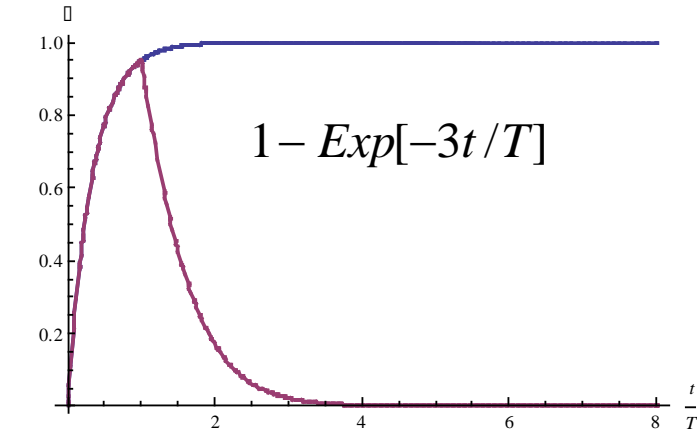

$h=75 \text{ km}$

$t_0 \approx h/c \approx 250 \text{ } \mu\text{secs}$

$$H(z,t) \propto K(t-t_0) - K(t-t_0-\tilde{t}) \approx \tilde{t}K'(t-t_0)$$

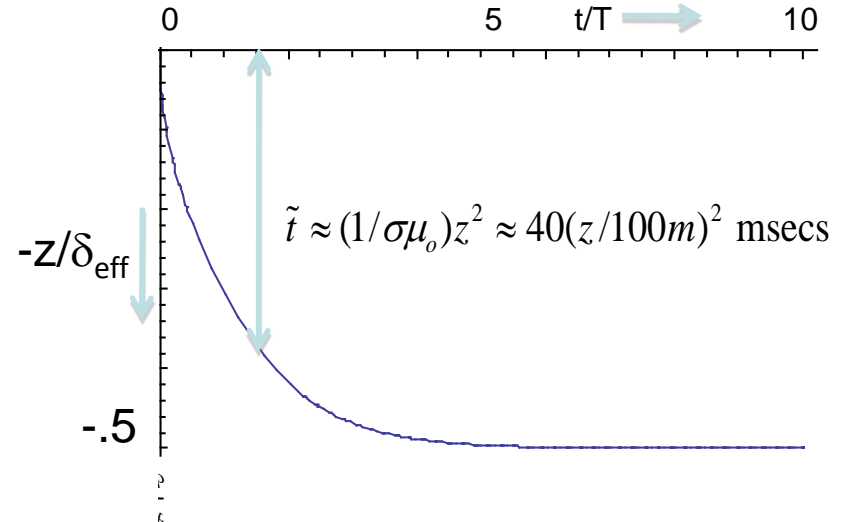
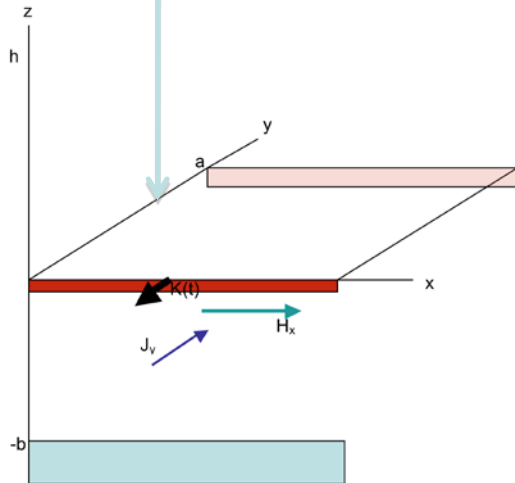

PRBR – Presentation to DARPA Director and Follow on

- **Why → Allow use of Commercial-Off-The-Shelf (COTS) Electronics with small feature size in LEO platforms**
- **Where → L=1.5-1.8**
- **How → Inject ULF (5-15 Hz) waves from the ground into L=1.5-1.8 shells to increase proton precipitation**
- **What does it take → Approximately 3-7 kW per $\Delta L=.1$ of injected power for a factor of 10 flux reduction in 2-3 years**
- **How to do it → Use ground based Horizontal Electric Dipoles (HED) or an array of 50-100 superconducting coils rotating at a 5-15 Hz rate**
- **Environmental Committee appointed by DARPA concluded that**
“the environmental effects (of PRBR), both on the middle atmosphere and the magnetic configuration of the earth and the magnetosphere, appear to be innocuous.”

Removing Energetic Protons

- Removal is accomplished in the same way as HANE electron remediation: increase the pitch angle diffusion rate so that protons precipitate into the atmosphere
- Pitch angle diffusion rate is increased by producing waves with the proper wavelength to resonate with energetic protons
 - ULF waves in the 1 – 10 Hz band
- Unlike HANE electrons, inner belt protons are produced by very slow processes so remediation can be done periodically (e.g. for 1-2 years every 10 years) as well as monitored
- Remediation of natural inner belt protons would have an immediate operational impact
- Similar ULF system could potentially be used for MeV electrons

SUPPLEMENTARY

Traditional HED Sources

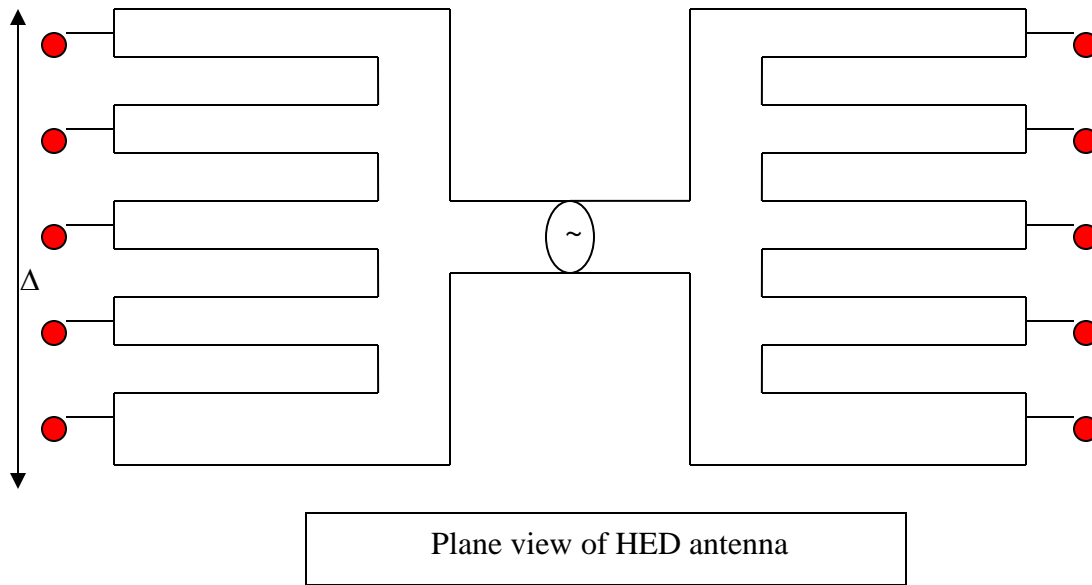

$$M_{eff} = \frac{l^2 \delta}{2(l + \delta)}$$

$$B \approx \mu \frac{M_{eff}}{h^3} \approx \frac{\mu l \delta}{2h^3} \frac{1}{(1 + \delta/l)}$$

$$I = 3.3(P / MW)^{1/2} (\sigma / 10^{-2})^{1/2} (L / km)^{1/2} \text{ kA}$$

$$Il^2 = 2 \times 10^{10} (P / MW)^{1/2} (\sigma / 10^{-2})^{1/2} (L / 2km)^{5/2} \text{ A} - m^2$$

Jason study Perkins et al.